



## GREASE TRAP S1

### PORTABLE GREASE TRAP

Grease and oils removal system is a totally engineered system for separating free floating grease and oils from drain water flows. The separated grease and oils are trapped within the stainless steel tank and can be manually recovered and guaranteed no odour with rubber seal. Only the "cleaned" water is allowed to pass through the system into the drain lines. Each unit also separates solid food waste into a removable basket. Austindo Grease Trap S1 can be used in a wide variety of applications from restaurants and food processing operations to many types of industrial operations.



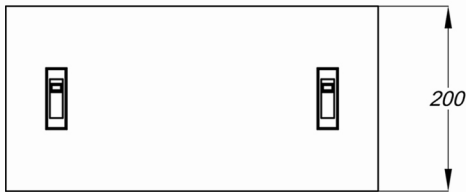
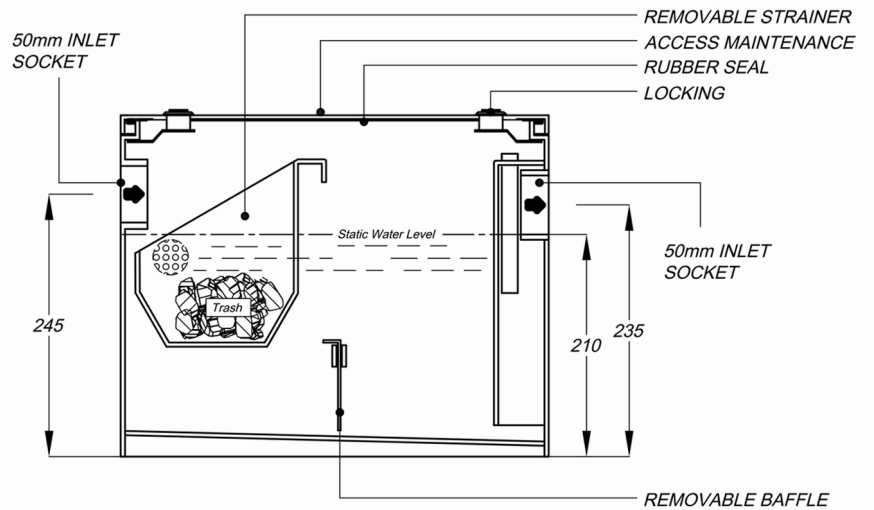
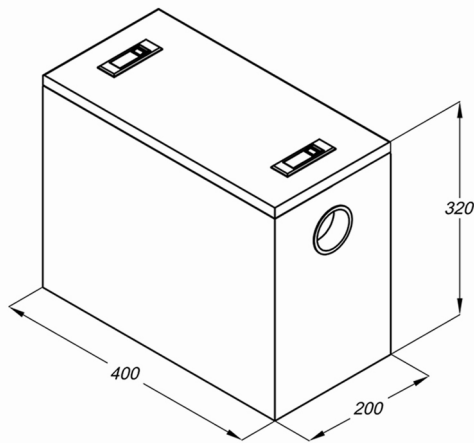

Length	Width	Height (TANK ONLY)	Inlet/Outlet	Inlet Height	Outlet Height	Max Flow (litres/min)
400	200	320	50	245	235	40

All Dimension in (mm)

## Installation

- Ensure basket can be easily removed
- Allow access to internal parts
- Ensure gravity flow away from unit
- Allow access to grease trap
- Ensure gravit foe away from unit



**PT Sanwell Austindo**

Jalan Gunung Sahari Raya 73C/8  
 Jakarta 10610  
 Telp: 021 424 5952 / Fax: 021 424 6061  
 Email: sanwell@austindo.id

**PT Austindo Perdana**

Jalan By Pass Ngurah Rai No. 1B-3  
 Simpang Dewa Ruci, Kuta - Bali  
 Phone: 0361 767 570 / Fax: 0361 767 571  
 Email: bali@austindo.id

[www.austindo.id](http://www.austindo.id)