

PUWAS

Public Washing Station

To combat and compliment the ever changing new normal, the PUWAS are units that will fullfill your daily needs to a more cleaner and cost effective alternative to every day hygiene, are easy to use and install.

Manufactured using high quality materials and finishing to assure long durability and latest ergonomic designs, the PUWAS can fit all indoor and outdoor conditions.

Supporting the campaign of CHSE - Cleanliness, Health, Safety and Environment, it's pre-packaged self contained unit comes complete with all accessories, easy installation details, just "plug in and wash away"



Free Standing Series



with Grab Bar

***"Modern Style
Hand-washing Station"***

Technical Specification

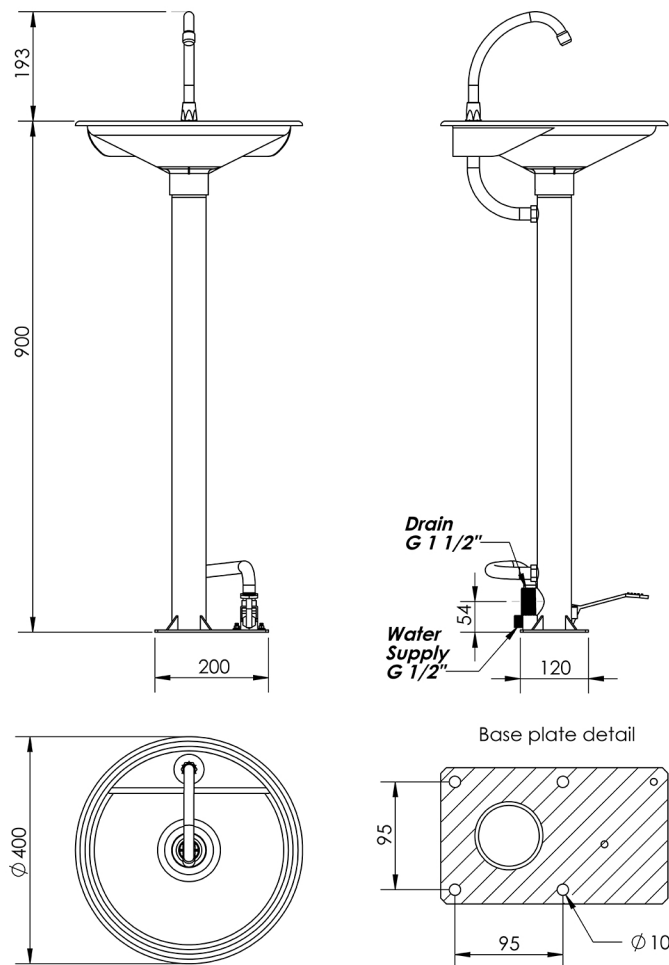
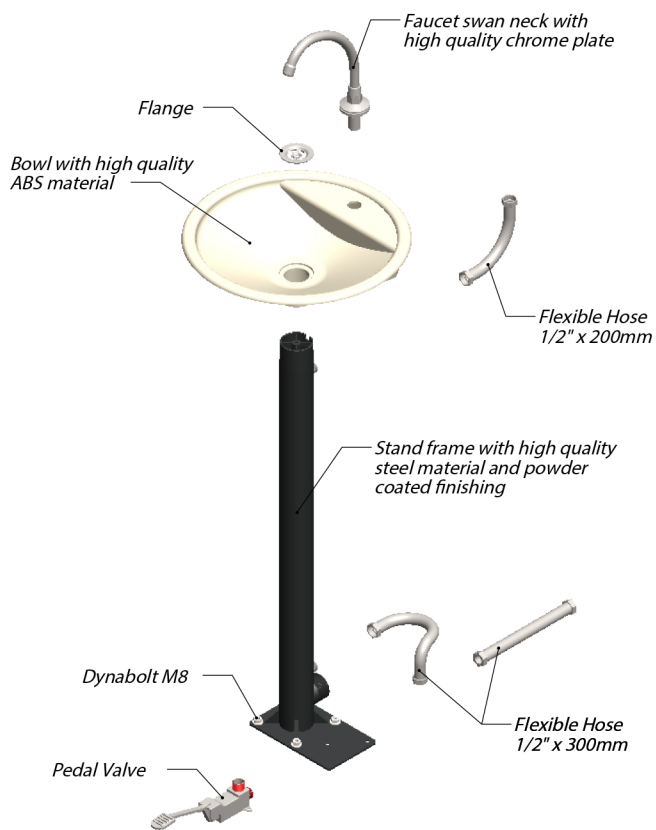

Bowl, made of **ABS Material**, optional colours available in ivory and yellow



Free standing set using high quality steel material with **powder coated finishing**, optional colours in green and black



Suitable for public areas, both indoor or outdoor, parking and park/jogging areas

CHSE

Supporting to implement the campaign of CHSE - Cleanliness, Health, Safety and Environment

Optional



Grab Bar



Soap Dispenser
(deck mounted)



Available for Children
(Height: 700mm)

Our Distributor

PT SANWELL AUSTINDO
Jalan Gunung Sahari Raya 73C-8
Jakarta 10610 - Indonesia
Tel 62(21) 424 5952, 424 5957
Fax 62 (21) 424 6061
email : sanwell@austindo.id